



# 191 G

CLASSIC

Single flavor counter top gravity fed machine to produce soft ice cream and frozen yogurt.  
**A must have**



Top quality components for great results

### High versatility

Give free space to your imagination and create cups as well as new soft delights and single portions

### A cool look

The machine can be adapted to all types of shop thanks to its new modern panel

### Electronic consistency control

Modify the consistency settings to adapt to all mix types



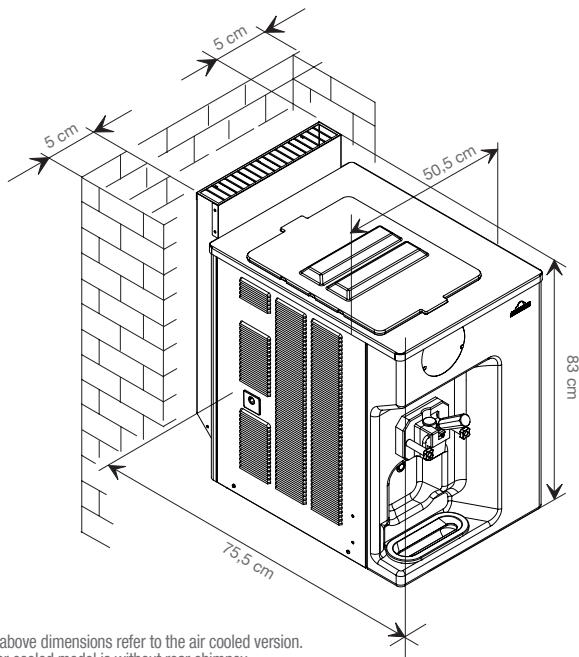

The above dimensions refer to the air cooled version. Water cooled model is without rear chimney

## Optional configurations

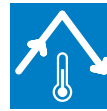

### Self-pasteurization

With our self-pasteurization system the machine can be cleaned and disassembled only 9 times per year



### Teorema Remote Control

It gives very important info about the machine, it facilitates the service system and helps the cleaning schedule



### Single portions dispensing head

With interchangeable nozzles to make single portions and delights



### Self closing device

The dispenser closes automatically stopping the flow of ice cream, eliminating any waste and preventing mess



### Only You

Customize your machine with your colours and logo



### Wash Kit

Optional tap above the tank to facilitate the cleaning operations

	Flavours	Mix Delivery System	Hourly production (75gr portions)	Tank Capacity lt	Cylinder Capacity lt	Nominal Power kW	Fuse Size A	Power Supply	Cooling System	Refrigerant	Net Weight kg
<b>191 G CLASSIC</b>	1	Gravity	230*	18	1,75	2,4	10	230/50/1**	Air/Water	R404	130

\* production capacity depends on the mix used and the room temperature

\*\* other voltages and cycles available upon request

## Features

Gravity fed system

Interactive display

Tank agitator

Tank rubber lid

POM beater

Adjustable ice cream flow

Direct expansion cooling cylinder

Defrost system

Rear panel chimney (air cooled version)

## Benefits

Control valves naturally add air to the mix producing a firm and dry ice cream having an overrun up to 40%

Communicates with the operator delivering instructions and data regarding machine performance

Prevents product stratification and helps to reduce foam by maintaining a fluid consistency

Light and handy. It facilitates the cleaning and filling operations

One piece POM beater, easy to clean, for a firm and dry product. Ideal for frozen yogurt

Adjustable product flow to meet your specific dispensing speed and volume requirements

Optimizes refrigeration efficiency for fast freeze downtime, less waste of product ensuring higher quality and energy saving

Possibility to heat the cylinder to simplify the cleaning procedure

Allows to optimize space and to place machines next to each other